



Application Note

AN_399

FT260 HID over I²C

Version 1.0

Issue Date: 2018-05-15

The FT260 is a USB device which supports I²C and UART communication through the standard USB HID interface, and also supports Microsoft's HID-over-I²C protocol. This document guides FT260 users on setting up the FT260 to connect a HID-over-I²C device.

Table of Contents

1	Introduction	3
1.1	Overview	3
1.2	HID Over I ² C Descriptor	3
1.3	FT260 Interface.....	4
1.4	FT260 Control and Operation.....	5
2	FT260 Configuration	7
2.1	Sample Configuration	8
3	Contact Information	10
	Appendix A – References	11
	Document References	11
	Acronyms and Abbreviations.....	11
	Appendix B – List of Tables & Figures	12
	List of Tables.....	12
	List of Figures	12
	Appendix C – Revision History	13

1 Introduction

1.1 Overview

Human Interface Device (HID) is one of the most popular USB device classes. This protocol was developed to simplify the process of connecting accessories such as a mouse, keyboard or touchpad to the PC. HID was originally developed to run on USB or Bluetooth. For Windows 8, Microsoft created a new type of device called "HID-over-I²C", which allows the device to communicate using the HID protocol over an Inter-Integrated Circuit (I²C) bus. The new "HID-over-I²C" devices are only supported natively by Microsoft Windows 8 or above.

FTDI introduces a new USB bridge chip, the FT260, which is able to connect a "HID-over-I²C" device via the I²C bus and uses FT260's EEPROM or Efuse for configuration.

FT260 helps to communicate USB HID requests from a PC to the device, and allows it to perform as a normal USB HID device without any additional coding. With FT260, an I²C slave that is compliant with the HID-over- I²C protocol can communicate directly with the USB HID class driver through the USB connection.

1.2 HID Over I²C Descriptor

In 2012, Microsoft developed "HID over I²C" that incorporated the simplicity of HID protocol and the popularity and robustness of I²C.

Microsoft defined the HID over I²C descriptor table as illustrated in Table 1.1 below. It is defined in Chapter 5 of the HID over I²C protocol specification v 1.0.1.

As described in its specification, the descriptor is the top-level mandatory descriptor and its purpose is to share key attributes of the DEVICE with the HOST.

Byte Offset	Field	Size (Bytes)	Type	Description
0	wHIDDescLength	2	WORD	The length, in unsigned bytes, of the complete HID Descriptor
2	bcdVersion	2	BCD	The version number, in binary coded decimal (BCD) format. DEVICE should default to 0x0100
4	wReportDescLength	2	WORD	The length, in unsigned bytes, of the Report Descriptor. Please note that FT260 only supports maximum size of 500 bytes.
6	wReportDescRegister	2	WORD	The register index containing the Report Descriptor on the DEVICE.
8	wInputRegister	2	WORD	This field identifies, in unsigned bytes, the register number to read the input report from the DEVICE.
10	wMaxInputLength	2	WORD	This field identifies in unsigned bytes the length of the largest Input Report to be read from the Input Register (Complex HID Devices will need various sized reports).
12	wOutputRegister	2	WORD	This field identifies, in unsigned bytes, the register number to send the output report to the DEVICE.
14	wMaxOutputLength	2	WORD	This field identifies in unsigned bytes the length of the largest output Report to be sent to the

				Output Register (Complex HID Devices will need various sized reports).
16	wCommandRegister	2	WORD	This field identifies, in unsigned bytes, the register number to send command requests to the DEVICE
18	wDataRegister	2	WORD	This field identifies in unsigned bytes the register number to exchange data with the Command Request
20	wVendorID	2	WORD	This field identifies the DEVICE manufacturers Vendor ID. Must be non-zero. FT260 has its own Vendor ID, which is forwarded to the host, the device does not need to define this value.
22	wProductID	2	WORD	This field identifies the DEVICE's unique model / Product ID. FT260 has its own Product ID, which is forwarded to the host.
24	wVersionID	2	WORD	This field identifies the DEVICE's firmware revision number. This field is not used by FT260 and is not forwarded to the host. The device does not need to define this value.
26	RESERVED	4	RESERVED	This field is reserved and should be set to 0.

Table 1.1 HID Descriptor Layout

1.3 FT260 Interface

In Figure 1.1 below, the FT260 connects directly to a device with an I²C interface and runs the HID over I²C protocol between the host and device, to achieve a simple and easy operation for users.

As illustrated, the FT260 acts as an interface bridge, which does not require any application programming hence it does not support any APIs and acts more like a plug and play device. Please note that the current design of FT260 supports single device connection.

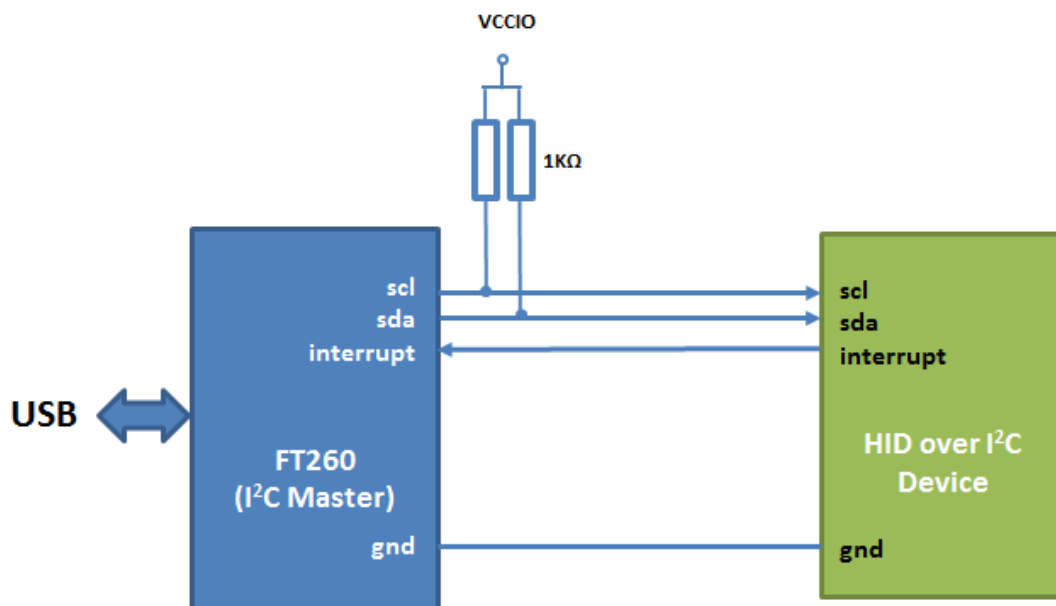

Figure 1.1 The FT260 connects with a HID over I²C device

1.4 FT260 Control and Operation

HID over I²C protocol is also a HID driver that runs at the host side, when a device is connected to a host via the FT260, the HID driver will take control of the FT260 and device without any specific application to be installed or operated at the host side.

When the FT260 is configured and powered up, it would start reading Device descriptors from the device immediately (FT260 operates I²C at standard mode: 100 kbit/s during initial process). When a device descriptor is obtained by the FT260, it will then send a HID report to the host. The maximum supported report size is 500 bytes. Figure 1.2 below shows the enumeration procedures of the FT260 when connected and powered up.

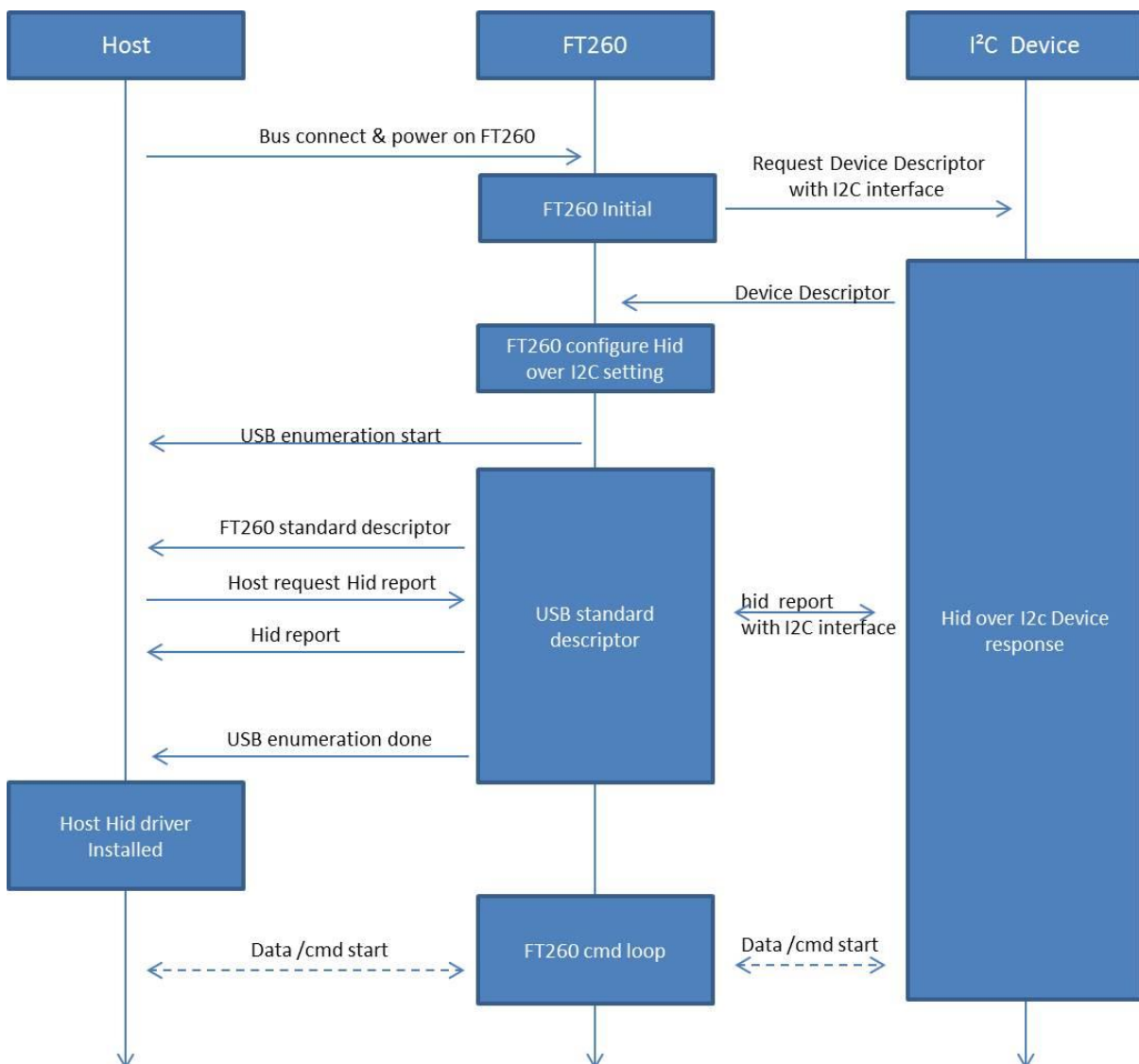

Figure 1.2 Hid over I²C of FT260 control

The host driver does a regular query of "Set/get _report", when the FT260 receives the get _report, the FT260 will check the Interrupt signal to report Device information. If the interrupt pin was triggered, the FT260 would query the device immediately, and packages received device data to send to the host via USB. The host driver can also do a "Set/Get" to the FT260 in the same process, the FT260 will query the Device according to Host request.

The communication of a typical connection is illustrated in Figure 1.3 as follows:

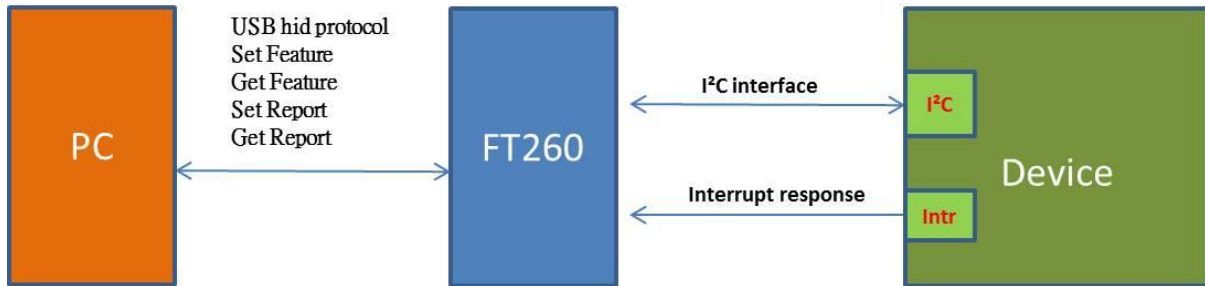

Figure 1.3 Hid over I²C of FT260 connect

2 FT260 Configuration

In order to enable the FT260 to support a HID-over-I²C device, the FT260 needs additional settings as the table 2.1 below shows. These parameters need to be programmed into its eFUSE or an external EEPROM.

Parameter	Notes
HID over I ² C address	The I ² C slave address of the target HID-over-I ² C device. The FT260 keeps 0h as its default value, and the address 0h means no HID-over-I ² C device is connected.
HID over I ² C Descriptor Address	The start address of the descriptor of the target HID-over-I ² C device. The HID-over-I ² C Descriptor is the top-level mandatory descriptor that every HID-over-I ² C device must have, and it shares key attributes of the device.
HID over I ² C Interrupt	Define the interrupt trigger type of the target HID-over-I ² C device. It can be: rising edge, falling edge, level-high, level-low.
HID over I ² C Option	According to Microsoft's HID over I ² C Protocol Specification, the following requests are optional: <ul style="list-style-type: none"> - GET_IDLE/SET_IDLE - GET_PROTOCOL/SET_PROTOCOL - SET_POWER This parameter indicates if the slave supports these optional requests.

Table 2.1 Parameters defined in eFUSE and EEPROM for FT260 HID-over-I²C support

Both eFUSE and EEPROM for the FT260 can be programmed over USB. This method is the same as for the MTP on other FTDI devices such as the FT-X series.

Please note that in order to program its eFUSE, the FT260 requires an additional programming voltage (3.8V) on its FSOURCE pin. The programming board, UMFTPD3A, provides a connection bridge between the FT260 and a USB host for supplying the power source, for timing control of the eFUSE, and also for communicating with the programming utility FT_Prog. Further details can be found in the [UMFTPD3A datasheet](#).

The FT_Prog utility can be downloaded from the following link in FTDI website -

http://www.ftdichip.com/Support/Utilities.htm#FT_Prog

Details of EEPROM and eFUSE can be found at the link below:

http://www.ftdichip.com/Support/Documents/DataSheets/ICs/DS_FT260.pdf

2.1 Sample Configuration

The FT260 may configure HID over I²C via two methods, EEPROM and eFUSE settings, depending on User case.

Taking Synaptic TM-P2819 as an example, which is a touchpad supporting the HID-over-I²C protocol. The following steps demonstrate the configuration of the FT260 for this device:

1. EEPROM Mode: To configure the device I²C address, HID over I²C report descriptor start address, and interrupt response in the EEPROM by FT_prog, please refer to Figure 2.1 below

I²C slave address: 0x20

Descriptor start address: 0x20

Interrupt type: level-low

HID over I²C options: not supported for all options.

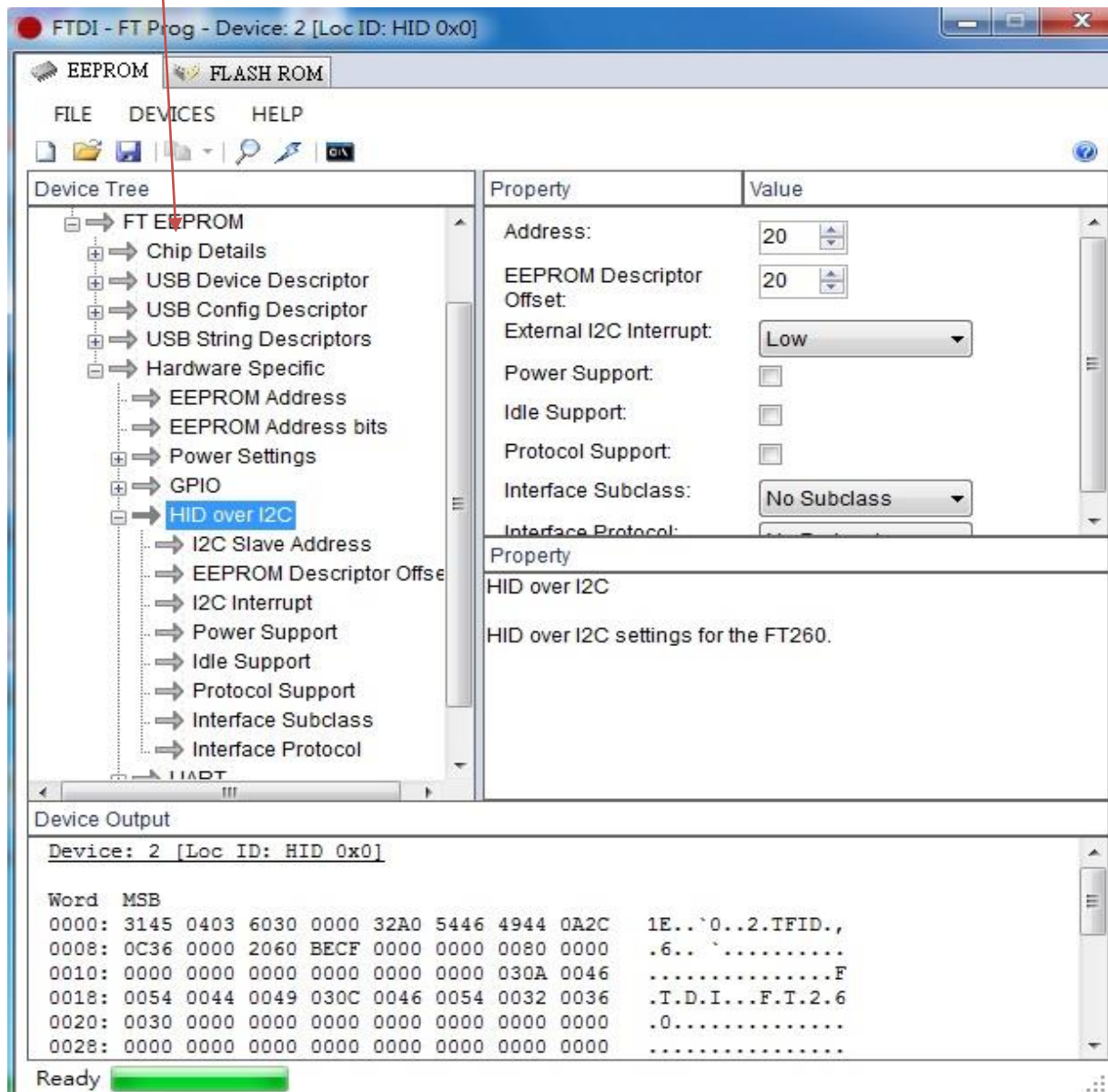

Figure 2.1 configure Hid over I²C on EEPROM

- 2. Efuse Mode: Mode :** To configure the device I²C address, HID over I²C report descriptor start address, and interrupt response in the eFUSE by FT_prog, refer to Figure 2.2 below
 Disable HID over I2C Settings: if user configured Efuse, disable option must be empty
 I²C slave address: 0x20
 Descriptor start address: 0x20
 Interrupt type: level-low
 HID over I²C options: not supported for all options.

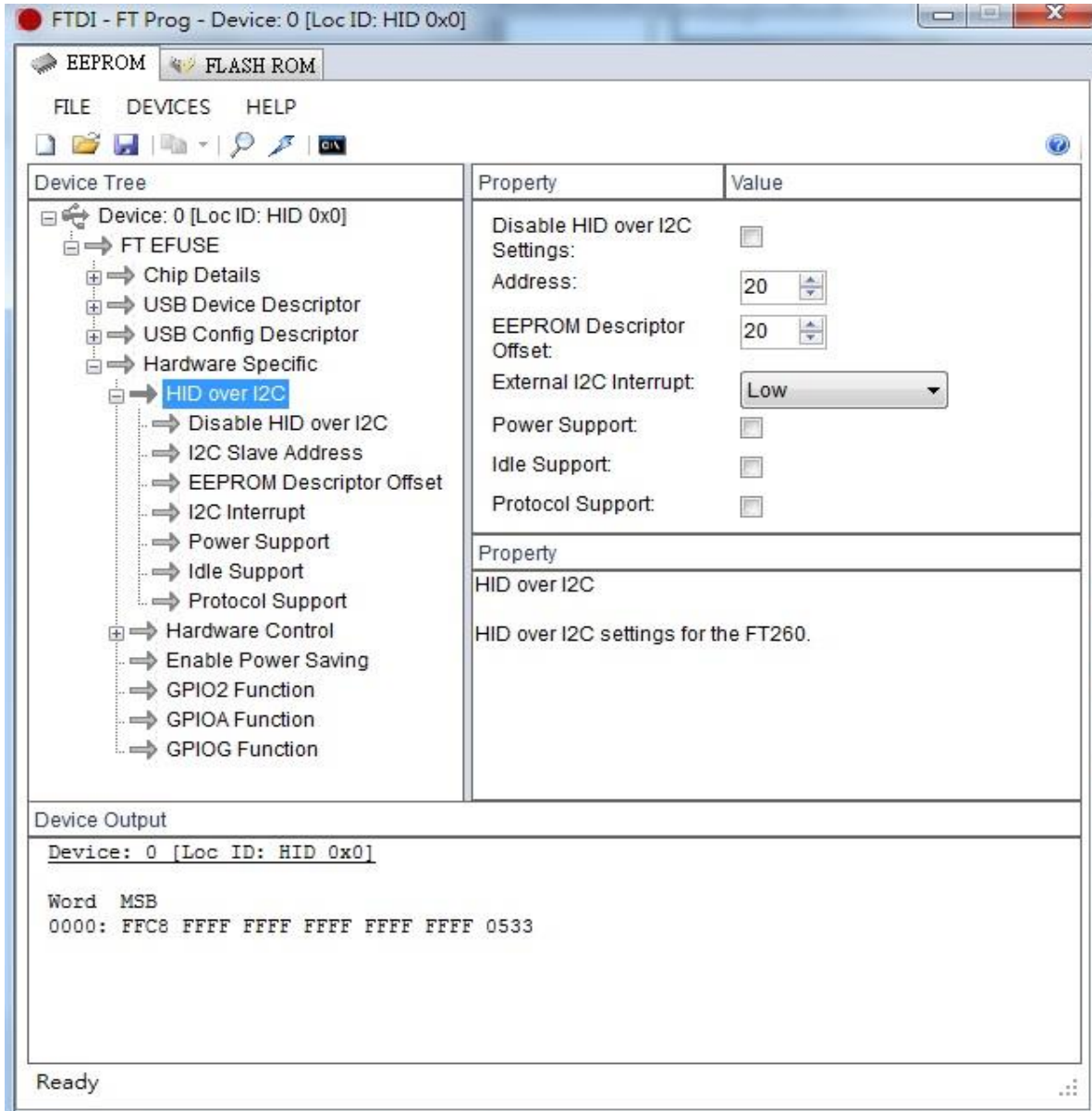

Figure 2.2 configure Hid over I²C on eFUSE

3 Contact Information

Head Office – Glasgow, UK

Future Technology Devices International Limited
Unit 1, 2 Seaward Place, Centurion Business Park
Glasgow G41 1HH
United Kingdom
Tel: +44 (0) 141 429 2777
Fax: +44 (0) 141 429 2758

E-mail (Sales) sales1@ftdichip.com
E-mail (Support) support1@ftdichip.com
E-mail (General Enquiries) admin1@ftdichip.com

Branch Office – Taipei, Taiwan

Future Technology Devices International Limited
(Taiwan)
2F, No. 516, Sec. 1, NeiHu Road
Taipei 114
Taiwan, R.O.C.
Tel: +886 (0) 2 8797 1330
Fax: +886 (0) 2 8751 9737

E-mail (Sales) tw.sales1@ftdichip.com
E-mail (Support) tw.support1@ftdichip.com
E-mail (General Enquiries) tw.admin1@ftdichip.com

Branch Office – Tigard, Oregon, USA

Future Technology Devices International Limited
(USA)
7130 SW Fir Loop
Tigard, OR 97223-8160
USA
Tel: +1 (503) 547 0988
Fax: +1 (503) 547 0987

E-Mail (Sales) us.sales@ftdichip.com
E-Mail (Support) us.support@ftdichip.com
E-Mail (General Enquiries) us.admin@ftdichip.com

Branch Office – Shanghai, China

Future Technology Devices International Limited
(China)
Room 1103, No. 666 West Huaihai Road,
Shanghai, 200052
China
Tel: +86 21 62351596
Fax: +86 21 62351595

E-mail (Sales) cn.sales@ftdichip.com
E-mail (Support) cn.support@ftdichip.com
E-mail (General Enquiries) cn.admin@ftdichip.com

Web Site

<http://ftdichip.com>

Distributor and Sales Representatives

Please visit the Sales Network page of the [FTDI Web site](#) for the contact details of our distributor(s) and sales representative(s) in your country.

System and equipment manufacturers and designers are responsible to ensure that their systems, and any Future Technology Devices International Ltd (FTDI) devices incorporated in their systems, meet all applicable safety, regulatory and system-level performance requirements. All application-related information in this document (including application descriptions, suggested FTDI devices and other materials) is provided for reference only. While FTDI has taken care to assure it is accurate, this information is subject to customer confirmation, and FTDI disclaims all liability for system designs and for any applications assistance provided by FTDI. Use of FTDI devices in life support and/or safety applications is entirely at the user's risk, and the user agrees to defend, indemnify and hold harmless FTDI from any and all damages, claims, suits or expense resulting from such use. This document is subject to change without notice. No freedom to use patents or other intellectual property rights is implied by the publication of this document. Neither the whole nor any part of the information contained in, or the product described in this document, may be adapted or reproduced in any material or electronic form without the prior written consent of the copyright holder. Future Technology Devices International Ltd, Unit 1, 2 Seaward Place, Centurion Business Park, Glasgow G41 1HH, United Kingdom. Scotland Registered Company Number: SC136640

Appendix A – References

Document References

[DS_FT260](#)

[UMFTPD3A Programmer Module Datasheet](#)

HID over I²C

Microsoft HID Over I2C Protocol Specification:

[https://msdn.microsoft.com/en-us/library/windows/hardware/dn642101\(v=vs.85\).aspx](https://msdn.microsoft.com/en-us/library/windows/hardware/dn642101(v=vs.85).aspx)

MSDN: HID-over-I2C Architecture and overview:

[https://msdn.microsoft.com/en-US/library/jj131705\(v=vs.85\).aspx](https://msdn.microsoft.com/en-US/library/jj131705(v=vs.85).aspx)

Acronyms and Abbreviations

Terms	Description
EEPROM	Electrically Erasable Programmable Read Only Memory
HID	Human Interface Device
I2C	Inter-Integrated Circuit
PC	Personal Computer
USB	Universal Serial Bus

Appendix B – List of Tables & Figures

List of Tables

Table 1.1 HID Descriptor Layout	4
Table 2.1 Parameters defined in eFUSE and EEPROM for FT260 HID-over-I ² C support	7

List of Figures

Figure 1.1 The FT260 connects with a HID over I ² C device.....	5
Figure 1.2 Hid over I ² C of FT260 control	5
Figure 1.3 Hid over I ² C of FT260 connect.....	6
Figure 2.1 configure Hid over I ² C on EEPROM	8
Figure 2.2 configure Hid over I ² C on eFUSE.....	9

Appendix C – Revision History

Document Title: AN_399 FT260 HID over I²C
Document Reference No.: FT_001293
Clearance No.: FTDI#543
Product Page: <http://www.ftdichip.com/FTProducts.htm>
Document Feedback: [Send Feedback](#)

Revision	Changes	Date
1.0	Initial Release	2018-05-15