



# **VINCULUM**

## BINDING USB TECHNOLOGIES

**Future Technology Devices International Ltd.**

# **Vinco Graphics Display Example**

## **Application Note AN\_161**

**Document Reference No.: FT\_000363**

**Version 2.0**

**Issue Date: 2011-04-15**

**This application note describes how the Vinco module can be used to display graphics on a LCD display.**

**Future Technology Devices International Ltd (FTDI)**

**Unit 1, 2 Seaward Place, Centurion Business Park, Glasgow, G41 1HH, United Kingdom**

**Tel.: +44 (0) 141 429 2777 Fax: + 44 (0) 141 429 2758**

**E-Mail (Support): [support1@ftdichip.com](mailto:support1@ftdichip.com)**

Use of FTDI devices in life support and/or safety applications is entirely at the user's risk, and the user agrees to defend, indemnify and hold harmless FTDI from any and all damages, claims, suits or expense resulting from such use.

## 1 Introduction

Vinco is a development module inspired by the Arduino concept and uses the Vinculum II, VNC2 device. Vinco uses a VNC2-64Q package to facilitate 38 GPIO options on 0.1" pitch sockets. Vinco is designed as a prototyping platform for VNC2 based designs and applications.

This application note describes an example of how to use the Vinco module to create and display graphic messages on a 128 x 64 pixel monochrome LCD display. The application note also provides "C" source code examples to help the user get started with their own specific application. This source code can be downloaded from the FTDI website at:

[http://ftdichip.com/Support/SoftwareExamples/VinculumIIProjects/Vinco\\_GLCD\\_SPI.zip](http://ftdichip.com/Support/SoftwareExamples/VinculumIIProjects/Vinco_GLCD_SPI.zip)

Note: Any sample code provided in this note is for illustration purposes and is not guaranteed or supported.



Figure 1.1 - VINCO

### 1.1 VNC2 Devices

VNC2 is the second of FTDI's Vinculum family of embedded dual USB host controller devices. The VNC2 device provides USB Host interfacing capability for a variety of different USB device classes including support for BOMS (bulk only mass storage), Printer and HID (human interface devices). For mass storage devices such as USB Flash drives, VNC2 transparently handles the FAT file structure.

Communication with non USB devices, such as a low cost microcontroller, is accomplished via either UART, SPI or parallel FIFO interfaces. VNC2 provides a new, cost effective solution for providing USB Host capability into products that previously did not have the hardware resources available.

VNC2 allows customers to develop their own firmware using the Vinculum II software development tool suite. These development tools provide compiler, assembler, linker and debugger tools complete within an integrated development environment (IDE).

The Vinculum-II VNC2 family of devices are available in Pb-free (RoHS compliant) 32-lead LQFP, 32-lead QFN, 48-lead LQFP, 48-lead QFN, 64-Lead LQFP and 64-lead QFN packages For more information on the ICs refer to <http://www.ftdichip.com/Products/ICs/VNC2.htm>

## 1.2 Topway LCD Display

This application example uses the Topway LM6059BCW 128 x 64 pixel monochrome LCD display mounted on a Vinulo\_Proto prototyping PCB. The LCD display is driven by a 3V3 power supply and 5 data / control lines. The data is clocked into the module serially.

For more information on Topway displays see <http://www.topwaydisplay.com/Pub/Manual/LM6059BCW-Manual-Rev0.3.pdf>

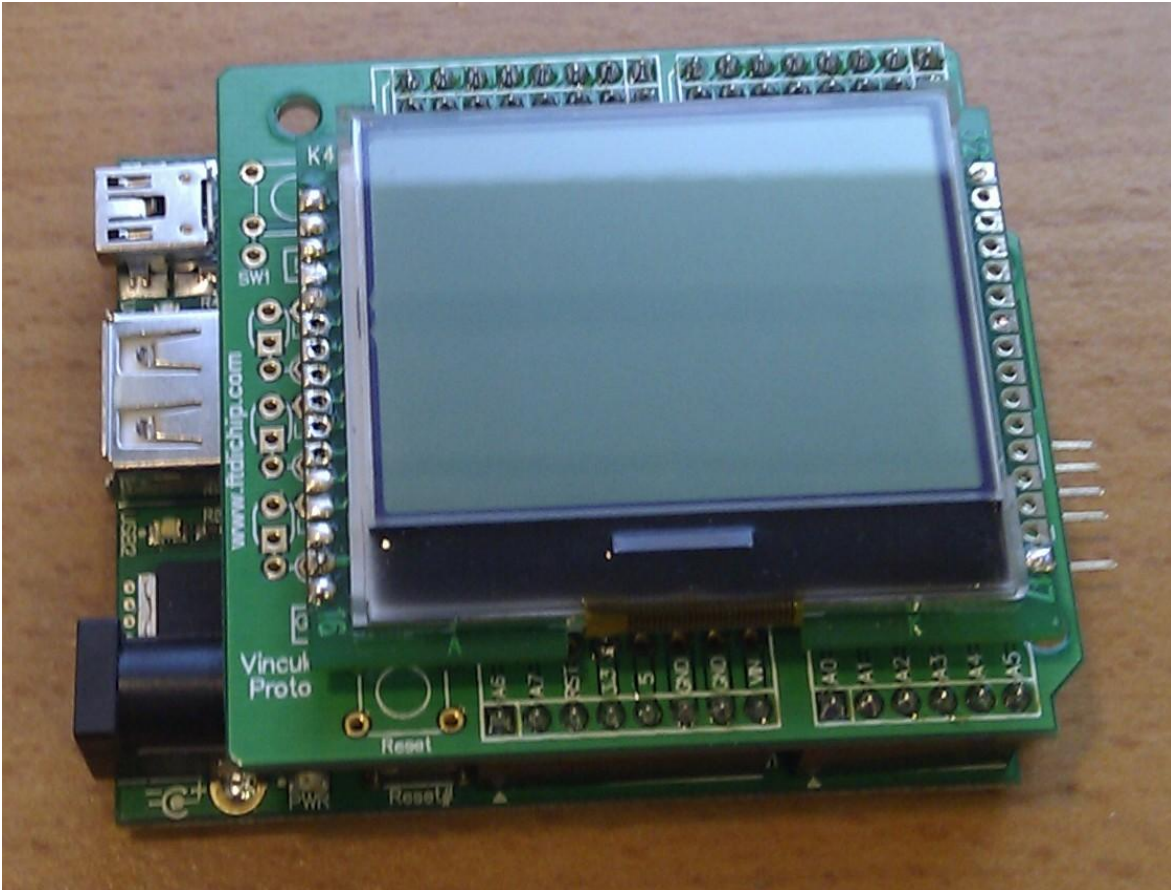

Figure 1.2 – Topway LM6059BCW LCD Module mounted on a Vinco\_Proto

## Table of Contents

<b>1</b>	<b>Introduction .....</b>	<b>1</b>
1.1	VNC2 Devices .....	1
1.2	Topway LCD Display .....	2
<b>2</b>	<b>Block Diagram .....</b>	<b>4</b>
<b>3</b>	<b>Interconnect .....</b>	<b>5</b>
3.1	Power .....	5
3.2	LCD Control .....	5
3.3	Debugger Interface.....	6
3.3.1	Signal Description - Debugger Interface .....	6
<b>4</b>	<b>Source code for the VNC2 writing to LCD Display .....</b>	<b>7</b>
4.1	VNC2 Initialisation .....	7
4.2	LCD Initialisation .....	8
4.3	Writing Command Instructions to the LCD .....	9
4.4	Writing Data Bytes to the LCD Display .....	9
4.5	Switching on the LCD Display.....	10
4.6	Switching off the LCD Display .....	10
4.7	Setting the LCD Contrast.....	10
4.8	Addressing the LCD .....	11
4.9	Clearing the Display .....	11
4.10	Displaying a graphical Logo .....	12
4.11	Displaying a line of text .....	13
4.12	Displaying another line of text.....	14
4.13	The Firmware function .....	15
<b>5</b>	<b>Programming Vinco.....</b>	<b>18</b>
<b>6</b>	<b>Running the firmware .....</b>	<b>19</b>
<b>7</b>	<b>Contact Information .....</b>	<b>20</b>
	Appendix A – References.....	21
	<a href="http://www.avrportal.com/?page=image2glcd">http://www.avrportal.com/?page=image2glcd</a> .....	21
	Appendix B – List of Figures and Tables .....	22
	List of Figures .....	22
	List of Tables .....	22
	Appendix C – Revision History.....	23
	<b>Appendix D Legal Disclaimer:.....</b>	<b>24</b>

## 2 Block Diagram

This block diagram, Figure 2.1, shows the interconnect required for the Vinco to drive the LCD display.

The Vinco debug port is used to load the firmware onto the module. (Note that this requires a VNC2 DEBUG MODULE [http://ftdichip.com/Support/Documents/DataSheets/Modules/DS\\_V2Debug\\_Module.pdf](http://ftdichip.com/Support/Documents/DataSheets/Modules/DS_V2Debug_Module.pdf) )

The serial interconnect between the two modules is used to transfer the image to be displayed on the LCD.

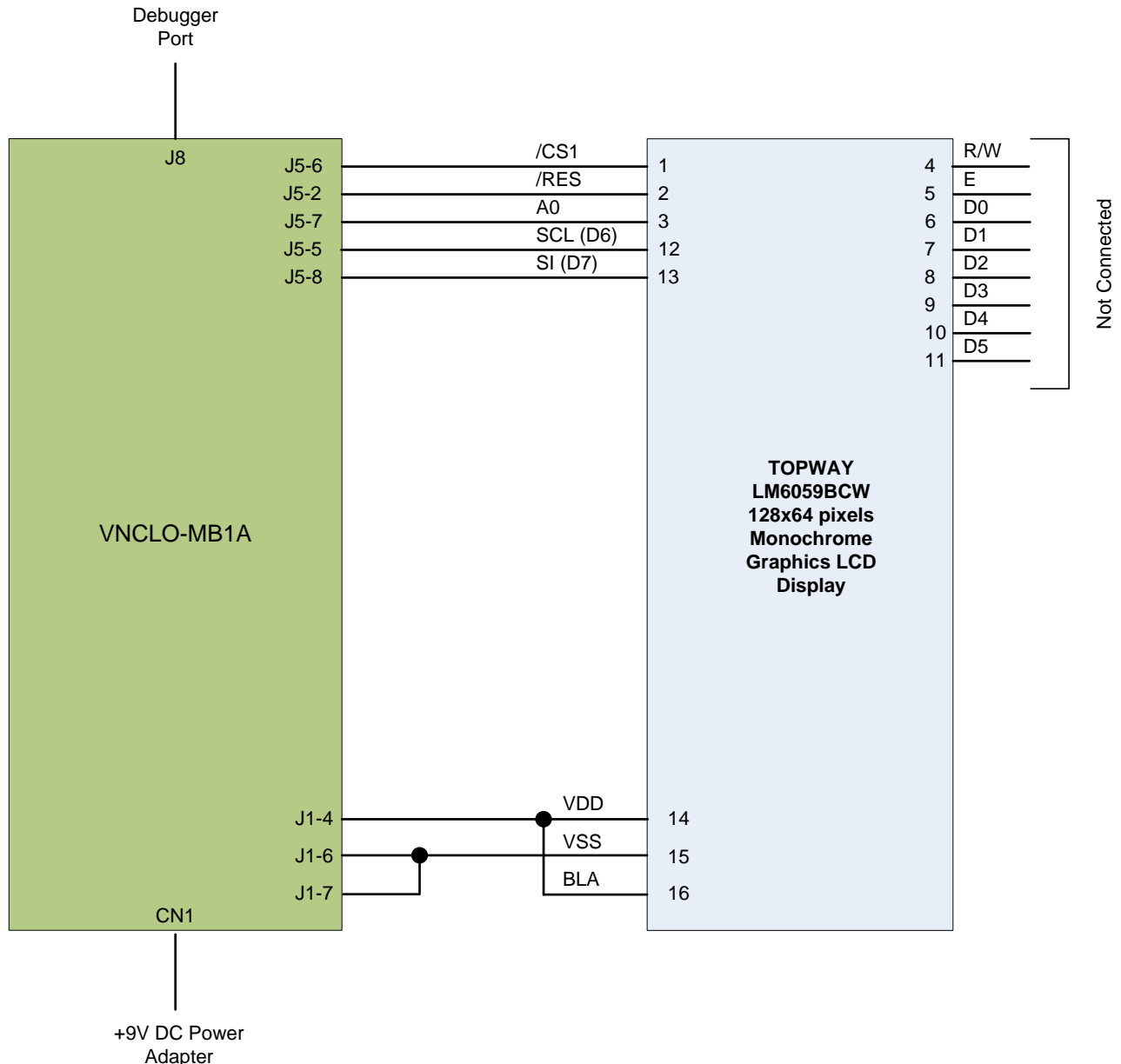

Figure 2.1 – Vinco Graphic Display Demo Block Diagram

### 3 Interconnect

#### 3.1 Power

The Vinco module may be powered from the USB port on CN3 (5V) or via an external power converter (9V/1A DC) to CN1 (for example the FTDI [VNCLO-PSU-UK](#))

As this application provides power to external circuitry (the LCD display), the Vinco is powered from an external 9V supply.

To ensure this power source is routed to the PCB, JP1 on the Vinco module must be set to the 2-3 position.

Power from the Vinco module is taken from J1 pin 4 to give a +3V3 supply for the Topway LCD display.

#### 3.2 LCD Control

The Topway LCD display may be controlled in either a synchronous serial data mode or an 8-bit data mode. This application uses the serial mode. The signals defined in the block diagram in section 2 are described in Table 3.1.

Signal	Function
/CS1	<b>Active low chip select for the LCD module</b>
/RES	<b>Active low reset for the LCD module</b>
A0	<b>Register select for the LCD module.</b> <b>0 = Display data</b> <b>1 = Control data</b>
SCL	<b>Serial clock input to LCD module.</b>
SI	<b>Serial data input to LCD module.</b>
BLA	<b>Positive supply for LCD Backlight.</b>

**Table 3.1 - Signal Name and Description – LCD Interface**

### 3.3 Debugger Interface

The purpose of the debugger interface is to provide access to the VNC2 silicon/firmware debugger. The debug interface can be accessed by connecting a *VNC2\_Debug\_Module* ([http://www.ftdichip.com/Support/Documents/DataSheets/ICs/DS\\_Vinculum-II.pdf](http://www.ftdichip.com/Support/Documents/DataSheets/ICs/DS_Vinculum-II.pdf)) to the J8 connector. This debug module gives access to the debugger through a USB connection to a PC via the Integrated Development Environment (IDE). The IDE is a graphical interface to the VNC2 software development tool-chain and gives the following debug capabilities through the debugger interface:

- Flash Erase, Write and Program.
- Application debug - application code can have breakpoints, be single stepped and can be halted.
- Detailed internal debug - memory and register read/write access.

The IDE may be downloaded, free of charge, from <http://www.ftdichip.com/Firmware/V2TC/VNC2toolchain.htm>

The Debugger Interface, and how to use it, is further described in the following applications Note [Vinculum-II Debug Interface Description](#)

#### 3.3.1 Signal Description - Debugger Interface

Table 3.2 shows the signals and pins description for the Debugger Interface pin header J8

<i>Pin No.</i>	<i>Name</i>	<i>Name On PCB</i>	<i>Type</i>	<i>Description</i>
J8-1	I00	DBG	I/O	Debugger Interface
J8-2	-	[Key]	-	Not connected. Used to make sure that the debug module is connected correctly.
J8-3	GND	GND	PWR	Module ground supply pin
J8-4	RESET#	RST#	Input	Can be used by an external device to reset the VNCL2. This pin is also used in combination with PROG# and the UART interface to program firmware into the VNC2.
J8-5	PROG#	PRG#	Input	This pin is used in combination with the RESET# pin and the UART interface to program firmware into the VNC2.
J8-6	5V0	VCC	PWR Input	5.0V module supply pin. This pin can be used to provide the 5.0V input to the V2DIP2-32 from the debugger interface when the V2DIP2-32 is not powered from the USB connector (VBUs) or the DIL connector pins J1-1 and J3-6.

Table 3.2 - Signal Name and Description – Debugger Interface

## 4 Source code for the VNC2 writing to LCD Display

The Vinculum II IDE is used to create application code to run on VNC2. This section gives some example source code, and explains its operation, used to drive the LCD display via the Vinco module.

Note the full project can be downloaded from:

<http://ftdichip.com/Support/SoftwareExamples/VinculumIIProjects.htm>

### 4.1 VNC2 Initialisation

When generating firmware for VNC2, the first steps are to enable the Vinculum Operating System (VOS), which controls the VNC2 services and device manager, defines the clock speed the core will use, and defines the VNC2 pins that will be used. This is done in the function labelled *main*. The "main" function for this application is shown as follows

```
void main(void)
{
    // GPIO context structure
    gpio_context_t gpioCtx;
    // SPI Master context structure
    spimaster_context_t spimCtx;

    // call VOS initialisation routines
    vos_init(10, VOS_TICK_INTERVAL, NUMBER_OF_DEVICES);
    vos_set_clock_frequency(VOS_48MHZ_CLOCK_FREQUENCY);

    // Setup IOMUX
    // Control port = GPIO PORT_B
    vos_iomux_define_output(63,IOMUX_OUT_GPIO_PORT_B_2); // PortB_2->LCD_RST#
    vos_iomux_define_output(13,IOMUX_OUT_GPIO_PORT_B_6); // PortB_6->LCD_A0
    // SPI pins
    vos_iomux_define_output(14,IOMUX_OUT_SPI_MASTER_CS_0); // LCD_CS#
    vos_iomux_define_output(15,IOMUX_OUT_SPI_MASTER_CLK); // LCD_CLK
    vos_iomux_define_output(16,IOMUX_OUT_SPI_MASTER_MOSI); // LCD_SDI

    // initialise device drivers
    spimCtx.buffer_size = VOS_BUFFER_SIZE_128_BYTES;
    spimaster_init(VOS_DEV_SPIM,&spimCtx);

    gpioCtx.port_identifier = GPIO_PORT_B;
    gpio_init(VOS_DEV_GPIOB,&gpioCtx);

    // create threads for firmware application (no parameters)
    tcbFirmware = vos_create_thread(29, SIZEOF_THREAD_MEMORY, firmware, 0);
    // start VOS scheduler
    vos_start_scheduler();
}
```



```
main_loop:  
    goto main_loop;  
}
```

Note: Starting the VOS scheduler is always the last thing to be done as all configuration must be complete before this starts.

## 4.2 LCD Initialisation

The LCD must be put into an initial known state to be able to accept new data and this initialisation is done in the `lcd_ini` function.

```
void lcd_ini(void)  
{  
    unsigned char data_byte;  
  
    // Hardware reset  
    data_byte = (0xFF & (~LCD_RST));  
    vos_dev_write(hGpioB, &data_byte, 1, NULL); // LCD Reset line - low  
    vos_delay_msecs(5);  
    data_byte = (data_byte | LCD_RST);  
    vos_dev_write(hGpioB, &data_byte, 1, NULL); // LCD Reset line - high  
    vos_delay_msecs(5);  
  
    cmd_buffer[0] = CMD_DISP_SET_BIAS; // Send 'Set Bias' command  
    cmd_buffer[1] = CMD_DISP_SCANDIR; // Send 'ADC Normal' command  
    cmd_buffer[2] = CMD_DISP_REV | 0x08; // Send 'Flip on Y' command  
    cmd_buffer[3] = CMD_DISP_LINE_ADDR; // Send 'Line addr = 0' command  
    write_lcd_cmd(cmd_buffer, 4);  
  
    cmd_buffer[0] = CMD_DISP_PWRCTRL | LCD_VCNV; // Send 'Power Ctrl' command  
    write_lcd_cmd(cmd_buffer, 1);  
    vos_delay_msecs(50);  
    cmd_buffer[0] = cmd_buffer[0] | LCD_VREG;  
    write_lcd_cmd(cmd_buffer, 1);  
    vos_delay_msecs(50);  
    cmd_buffer[0] = cmd_buffer[0] | LCD_VFOL;  
    write_lcd_cmd(cmd_buffer, 1);  
    vos_delay_msecs(50);  
  
    cmd_buffer[0] = CMD_DISP_VREG_RES_RATIO | 0x06; // Send 'Regulator Resistor Select' command  
    cmd_buffer[1] = CMD_DISP_EVOLUME_MODE; // Send 'Set Reference Voltage' command  
    cmd_buffer[2] = LCD_EVOLUME_VALUE;  
    cmd_buffer[3] = CMD_DISP_ON; // Send 'Display On' command
```

```
write_lcd_cmd(cmd_buffer, 4);  
vos_delay_msecs(50);  
  
lcd_clear();  
  
SetPageAddress(0);  
SetColumnAddress(0);  
SetLineAddress(0);  
}
```

The data values which can be sent to the LCD are defined in the LCD user manual. The `write_lcd_cmd(cmd_buffer, 1);` is an instruction to call the `write_LCD_cmd` function so that data may be moved from the VNC2 to the LCD over the VNC2 SPI interface.

### 4.3 Writing Command Instructions to the LCD

```
void write_lcd_cmd(unsigned char *cmd, unsigned char len)  
{  
    unsigned char ctrl_byte;  
  
    ctrl_byte = (~LCD_A0)|LCD_RST;  
    vos_dev_write(hGpioB,&ctrl_byte,1,NULL); // Set A0 and RESET line high  
    spim_iocb.ioctl_code = VOS_IOCTL_SPI_MASTER_SS_0;  
    spim_iocb.set.param = SPI_MASTER_SS_ENABLE;  
    vos_dev_ioctl(hSPIm,&spim_iocb);  
    vos_dev_write(hSPIm, cmd, (len&0x00FF), NULL);  
    spim_iocb.ioctl_code = VOS_IOCTL_SPI_MASTER_SS_0;  
    spim_iocb.set.param = SPI_MASTER_SS_DISABLE;  
    vos_dev_ioctl(hSPIm,&spim_iocb);  
}
```

`vos_dev_write` is a VOS defined command for writing out data. The `hGPIO` is the handle for the GPIO driver that is used to control the A0 and RESET pins of the LCD. The `hSPIm` is the handle for the SPI master driver that is used to send the clocked serial data to the LCD display .

### 4.4 Writing Data Bytes to the LCD Display

The main difference with writing data to the LCD as opposed to commands is the state of the A0 pin controlled by the VNC2 GPIO.

```
void write_lcd_data(unsigned char *data, unsigned char len)  
{  
    unsigned char ctrl_byte;  
  
    ctrl_byte = LCD_A0|LCD_RST;
```

```
vos_dev_write(hGpioB,&ctrl_byte,1,NULL); // Set A0 low and RESET line high
spim_iocb.ioctl_code = VOS_IOCTL_SPI_MASTER_SS_0;
spim_iocb.set.param = SPI_MASTER_SS_ENABLE;
vos_dev_ioctl(hSPIm,&spim_iocb);
vos_dev_write(hSPIm, data, (len&0x00FF), NULL);
spim_iocb.ioctl_code = VOS_IOCTL_SPI_MASTER_SS_0;
spim_iocb.set.param = SPI_MASTER_SS_DISABLE;
vos_dev_ioctl(hSPIm,&spim_iocb);
}
```

## 4.5 Switching on the LCD Display

This is switching on the LCD backlight.

```
void lcd_on(void)
{
    cmd_buffer[0] = CMD_DISP_ON; // Send 'Display On' command
    write_lcd_cmd(cmd_buffer, 1);
}
```

## 4.6 Switching off the LCD Display

This is switching off the LCD backlight.

```
void lcd_off(void)
{
    cmd_buffer[0] = CMD_DISP_OFF; // Send 'Display Off' command
    write_lcd_cmd(cmd_buffer, 1);
}
```

## 4.7 Setting the LCD Contrast

This is sending a command to the LCD display to define how bright the image appears.

```
void lcd_set_contrast(unsigned char contrast_value)
{
    cmd_buffer[0] = CMD_DISP_EVOLUME_MODE; // Send 'Set Reference Voltage' command
    cmd_buffer[1] = contrast_value;
    write_lcd_cmd(cmd_buffer, 2);
}
```

## 4.8 Addressing the LCD

The LCD is notionally like a large memory where each memory location equals a pixel. You can address this memory (pixel) by pages or by lines and columns. The following functions provide the addressing information.

```
void SetPageAddress(unsigned char page)
{
    cmd_buffer[0] = CMD_DISP_PAGE_ADDR | (page &0x0F);
    write_lcd_cmd(cmd_buffer, 1);
}
//-----
void SetColumnAddress(unsigned char column)
{
    cmd_buffer[0] = CMD_DISP_COLADDR_H | (column>>4);
    cmd_buffer[1] = CMD_DISP_COLADDR_L | (column&0x0F);
    write_lcd_cmd(cmd_buffer, 2);
}
//-----
void SetLineAddress(unsigned char line)
{
    cmd_buffer[0] = CMD_DISP_LINE_ADDR | line;
    write_lcd_cmd(cmd_buffer, 1);
}
```

## 4.9 Clearing the Display

Using the following functions the LCD display can be cleared or have individual lines cleared.

```
void lcd_clear(void)
{
    unsigned char i;

    for(i=0;i<128;i++)
    {
        lcd_buffer[i]=0;
    }
    for(i=0;i<8;i++)
    {
        SetPageAddress(i);
        SetColumnAddress(0);
        SetLineAddress(0);
        write_lcd_data(lcd_buffer, 128);
    }
}
```

```
}  
//-----  
void lcd_clear_line(unsigned char y)  
{  
    unsigned char i;  
  
    for(i=0;i<128;i++)  
    {  
        lcd_buffer[i]=0;  
    }  
    SetPageAddress(y);  
    SetColumnAddress(0);  
    write_lcd_data(lcd_buffer, 128);  
}
```

## 4.10 Displaying a graphical Logo

IMAGE2GLCD is a free tool from the internet used to create a graphical bitmap. The bitmap generated in this project was the Vinculum logo which was stored in V2Logo.h for printing out to the LCD screen with this function.

```
void show_logo(unsigned short delay1)  
{  
    unsigned char i,j;  
    unsigned short temp;  
  
    SetPageAddress(0);  
    SetColumnAddress(0);  
    for (j=0;j<8;j++)  
    {  
        SetPageAddress(j);  
        SetColumnAddress(0);  
        for (i=0;i<128;i++)  
        {  
            temp=128*j;  
            temp+=i;  
            lcd_buffer[i]= img[temp];  
        }  
        write_lcd_data(lcd_buffer,128);  
        vos_delay_msecs(delay1);  
    }  
}
```

## 4.11 Displaying a line of text

As well as graphics this example shows how to display text with different font sizes.

This function uses a character bit map 8x8 pixels in size.

```
void LCDprintf8x8(unsigned char x,unsigned char y,unsigned char inv,unsigned char *Str)
{
    unsigned char m,n;
    unsigned short yy;

    SetPageAddress(y); // Line where to display the string (0..7)
    SetColumnAddress(x); // Horizontal offset (0..127)
    n=x;
    while(*Str != '\0') // While not the end of the string
    {
        if((n+8)>127) // Check if one more character can be displayed
        {
            break;
        }
        else
        {
            yy = *Str; // Get ASCII value
            yy = (yy*8); // Calculate the position of charecter bitmap
            for(m=0; m<8; m++)
            {
                lcd_buffer[n]= font8x8[yy+m]; // Copy character bitmap to display buffer
                if(inv)
                {
                    lcd_buffer[n]= (~lcd_buffer[n]); // Copy character bitmap to display buffer
                }
                n++;
            }
            ++Str; // Increment the pointer
        }
    }
    write_lcd_data(lcd_buffer, (n+1)); // Send buffer to the display.
}
```

## 4.12 Displaying another line of text

This function uses a character bit map 5x7 pixels in size. This is equivalent to creating a different font.

```
void LCDprintf5x7(unsigned char x,unsigned char y,unsigned char inv,unsigned char *Str)
{
    unsigned char m,n;
    unsigned short yy;

    SetPageAddress(y); // Line where to display the string (0..7)
    SetColumnAddress(x); // Horizontal offset (0..127)
    n=x;
    while(*Str != '\0') // While not the end of the string
    {
        if((n+5)>127) // Check if one more character can be displayed
        {
            break;
        }
        else
        {
            yy = *Str; // Get ASCII value
            yy = (yy-32)*5; // Calculate the position of charecter bitmap
            for(m=0; m<5; m++)
            {
                lcd_buffer[n]= font5x7[yy+m]; // Copy character bitmap to display buffer
                if(inv)
                {
                    lcd_buffer[n]= (~lcd_buffer[n]); // Copy character bitmap to display buffer
                }
                n++;
            }
            ++Str; // Increment the pointer
        }
    }
    write_lcd_data(lcd_buffer, (n+1)); // Send buffer to the display.
}
```

## 4.13 The Firmware function

This function is the main thread calling all the other functions to create a scrolling display.

```
void firmware(void)
{
    // GPIO IOCTL request block
    gpio_ioctl_cb_t gpio_iocb;

    // general purpose variables
    unsigned char i;

    // find and open GPIO device port B
    hGpioB = vos_dev_open(VOS_DEV_GPIOB);

    gpio_iocb.ioctl_code = VOS_IOCTL_GPIO_SET_MASK;
    gpio_iocb.value = 0x44;    // set bit 2 and 6 as outputs, all other as
                               inputs
    vos_dev_ioctl(hGpioB, &gpio_iocb);

    //*****
    // INITIALISE SPI MASTER PARAMETERS
    //*****

    // open SPI Master and get a handle
    hSPIm = vos_dev_open(VOS_DEV_SPIM);

    // enable DMA
    spim_iocb.ioctl_code = VOS_IOCTL_COMMON_ENABLE_DMA;
    vos_dev_ioctl(hSPIm, &spim_iocb);

    // set clock phase
    spim_iocb.ioctl_code = VOS_IOCTL_SPI_MASTER_SCK_CPHA;
    spim_iocb.set.param = SPI_MASTER_SCK_CPHA_1;
    vos_dev_ioctl(hSPIm, &spim_iocb);

    // set clock polarity
    spim_iocb.ioctl_code = VOS_IOCTL_SPI_MASTER_SCK_CPOL;
    spim_iocb.set.param = SPI_MASTER_SCK_CPOL_1;
    vos_dev_ioctl(hSPIm, &spim_iocb);

    // set data order
    spim_iocb.ioctl_code = VOS_IOCTL_SPI_MASTER_DATA_ORDER;
    spim_iocb.set.param = SPI_MASTER_DATA_ORDER_MSB;
    vos_dev_ioctl(hSPIm, &spim_iocb);

    // set clock rate
    spim_iocb.ioctl_code = VOS_IOCTL_SPI_MASTER_SET_SCK_FREQUENCY;
    spim_iocb.set.spi_master_sck_freq = 1000000;
    vos_dev_ioctl(hSPIm, &spim_iocb);

    spim_iocb.ioctl_code = VOS_IOCTL_SPI_MASTER_SET_DATA_DELAY;
    spim_iocb.set.param = 0;
    vos_dev_ioctl(hSPIm, &spim_iocb);

    // set chip select
    spim_iocb.ioctl_code = VOS_IOCTL_SPI_MASTER_SS_0;
    spim_iocb.set.param = SPI_MASTER_SS_DISABLE;
    vos_dev_ioctl(hSPIm, &spim_iocb);

    spim_iocb.ioctl_code = VOS_IOCTL_SPI_MASTER_SS_1;
```



```
spim_iocb.set.param = SPI_MASTER_SS_DISABLE;
vos_dev_ioctl(hSPIm, &spim_iocb);

lcd_ini();

while(1)
{
    lcd_clear();
    show_logo(200);
    vos_delay_msecs(2000);
    i = LCD_EVOLUME_VALUE;
    while(i>0)
    {
        lcd_set_contrast(i);
        i--;
        vos_delay_msecs(100);
    }
    lcd_off();
    lcd_clear();
    LCDprintf8x8(0,1,0,LINE1);
    LCDprintf8x8(0,2,0,LINE2);
    LCDprintf5x7(0,3,0,LINE3);
    LCDprintf5x7(0,4,0,LINE4);
    lcd_on();
    i=0;
    while(i<(LCD_EVOLUME_VALUE+1))
    {
        lcd_set_contrast(i);
        i++;
        vos_delay_msecs(100);
    }
    vos_delay_msecs(1000);
    for(i=0;i<3;i++)
    {
        lcd_off();
        vos_delay_msecs(330);
        lcd_on();
        vos_delay_msecs(660);
    }
    // Shift display 8 lines up
    for(i=0;i<8;i++)
    {
        SetLineAddress(i);
        vos_delay_msecs(200);
    }
    lcd_clear_line(1);
    LCDprintf5x7(0,0,0,LINE5);
    // Shift display 8 lines up
    for(i=0;i<8;i++)
    {
        SetLineAddress(i+8);
        vos_delay_msecs(200);
    }
    lcd_clear_line(2);
    LCDprintf5x7(0,1,0,LINE6);
    for(i=0;i<8;i++)
    {
        SetLineAddress(i+16);
        vos_delay_msecs(200);
    }
    lcd_clear_line(3);
```

```
LCDprintf5x7(0,2,0,LINE7);
for(i=0;i<8;i++)
{
    SetLineAddress(i+24);
    vos_delay_msecs(200);
}
lcd_clear_line(4);
LCDprintf5x7(0,3,0,LINE8);
for(i=0;i<8;i++)
{
    SetLineAddress(i+32);
    vos_delay_msecs(200);
}
lcd_clear_line(5);
LCDprintf5x7(0,4,0,LINE9);
for(i=0;i<8;i++)
{
    SetLineAddress(i+40);
    vos_delay_msecs(200);
}
lcd_clear_line(6);
LCDprintf5x7(0,5,0,LINE10);
for(i=0;i<8;i++)
{
    SetLineAddress(i+48);
    vos_delay_msecs(200);
}
lcd_clear_line(7);
LCDprintf5x7(0,6,0,LINE11);
for(i=0;i<8;i++)
{
    SetLineAddress(i+56);
    vos_delay_msecs(200);
}
lcd_clear_line(0);
LCDprintf5x7(0,7,0,LINE12);

vos_delay_msecs(2000);

}
}
```

## 5 Programming Vinco

When Vinco has been connected to the LCD panel and the firmware has been built in the IDE, the next step is to transfer the .ROM file generated by the IDE to the Vinco module. The IDE generates the .ROM file with a single button click of the "Build" button.

Connect the USB port of the VNC2 Debug Module to a PC and load the free FTDI drivers for the FT232R device on the debug module. This will happen automatically via Windows Update if you are connected to their internet. Otherwise refer to the installation guide for your OS:

<http://www.ftdichip.com/Support/Documents/InstallGuides.htm>

The IDE should now automatically detect the VNC2 debug module.

Connect the other end of the VNC2 Debug Module to the J8 connector of the Vinco.

Use the IDE FLASH button to load the .ROM file into the Vinco. A getting started guide for using the Vinculum IDE may be downloaded from:

[http://www.ftdichip.com/Support/Documents/AppNotes/AN\\_142\\_Vinculum-II\\_Tool\\_Chain\\_Getting\\_Started\\_Guide.pdf](http://www.ftdichip.com/Support/Documents/AppNotes/AN_142_Vinculum-II_Tool_Chain_Getting_Started_Guide.pdf)

The IDE will report back a successful programming. At this point the VNC2 Debug module may be removed from the Vinco J8 connector.

The .rom file can also be downloaded from the following location:

<http://ftdichip.com/Support/SoftwareExamples/VinculumIIPrompts.htm>

## 6 Running the firmware

The Vinco may be reset by power cycling the unit and then the firmware will run...

The user will observe the Vinco logo displayed on the LCD screen.

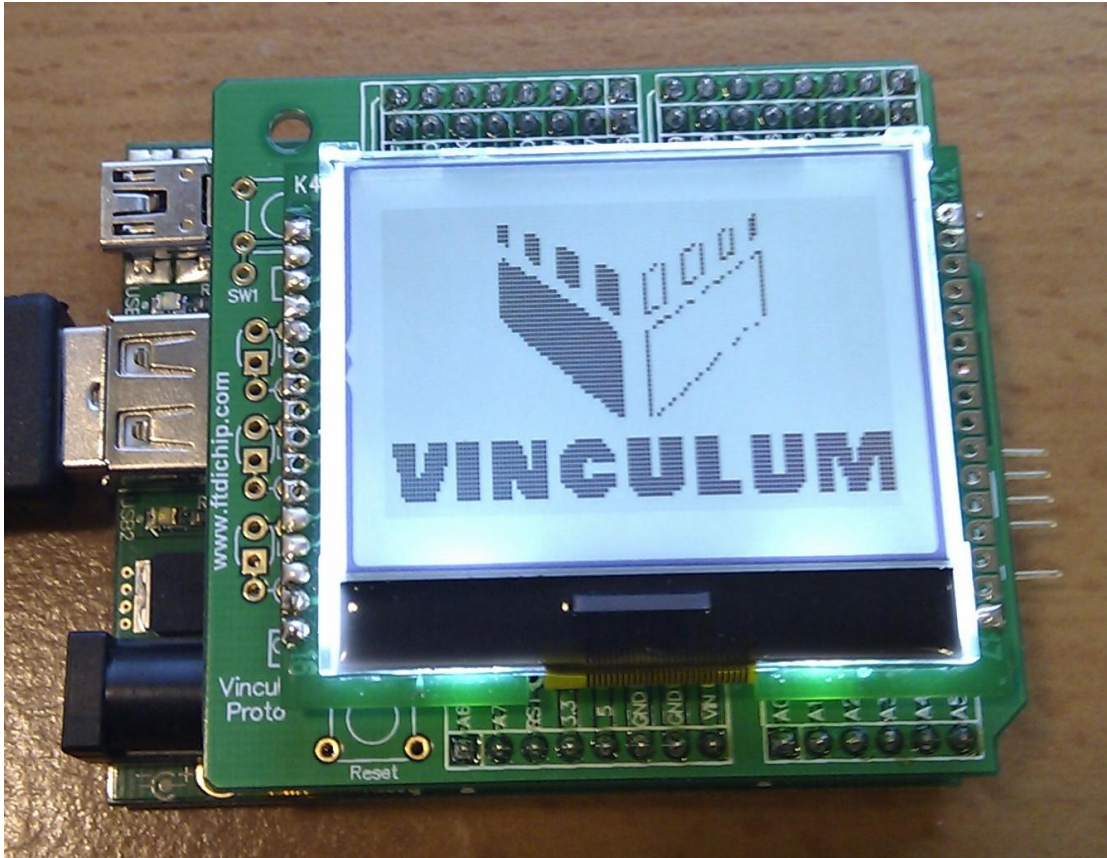

**Figure 6.1 – Vinco Graphic Display Demo**

It is left to the user to experiment with changing the displayed images by modifying the sample project code.

## 7 Contact Information

### Head Office – Glasgow, UK

Future Technology Devices International Limited  
Unit 1, 2 Seaward Place,  
Centurion Business Park  
Glasgow, G41 1HH  
United Kingdom  
Tel: +44 (0) 141 429 2777  
Fax: +44 (0) 141 429 2758

E-mail (Sales) [sales1@ftdichip.com](mailto:sales1@ftdichip.com)  
E-mail (Support) [support1@ftdichip.com](mailto:support1@ftdichip.com)  
E-mail (General Enquiries) [admin1@ftdichip.com](mailto:admin1@ftdichip.com)  
Web Site URL <http://www.ftdichip.com>  
Web Shop URL <http://www.ftdichip.com>

### Branch Office – Taipei, Taiwan

Future Technology Devices International Limited (Taiwan)  
2F, No 516, Sec. 1 NeiHu Road  
Taipei 114  
Taiwan, R.O.C.  
Tel: +886 (0) 2 8791 3570  
Fax: +886 (0) 2 8791 3576

E-mail (Sales) [tw.sales1@ftdichip.com](mailto:tw.sales1@ftdichip.com)  
E-mail (Support) [tw.support1@ftdichip.com](mailto:tw.support1@ftdichip.com)  
E-mail (General Enquiries) [tw.admin1@ftdichip.com](mailto:tw.admin1@ftdichip.com)  
Web Site URL <http://www.ftdichip.com>

### Branch Office – Hillsboro, Oregon, USA

Future Technology Devices International Limited (USA)  
7235 NW Evergreen Parkway, Suite 600  
Hillsboro, OR 97123-5803  
USA  
Tel: +1 (503) 547 0988  
Fax: +1 (503) 547 0987

E-Mail (Sales) [us.sales@ftdichip.com](mailto:us.sales@ftdichip.com)  
E-Mail (Support) [us.support@ftdichip.com](mailto:us.support@ftdichip.com)  
E-Mail (General Enquiries) [us.admin@ftdichip.com](mailto:us.admin@ftdichip.com)  
Web Site URL <http://www.ftdichip.com>

### Branch Office – Shanghai, China

Future Technology Devices International Limited (China)  
Room 408, 317 Xianxia Road,  
ChangNing District,  
ShangHai, China

Tel: +86 (21) 62351596  
Fax: +86(21) 62351595

E-Mail (Sales): [cn.sales@ftdichip.com](mailto:cn.sales@ftdichip.com)  
E-Mail (Support): [cn.support@ftdichip.com](mailto:cn.support@ftdichip.com)  
E-Mail (General Enquiries): [cn.admin1@ftdichip.com](mailto:cn.admin1@ftdichip.com)  
Web Site URL <http://www.ftdichip.com>

### Distributor and Sales Representatives

Please visit the Sales Network page of the FTDI Web site for the contact details of our distributor(s) and sales representative(s) in your country.

---

## Appendix A – References

Application and Technical Notes available at  
<http://www.ftdichip.com/Support/Documents/AppNotes.htm>

[Vinco datasheet](#)

[http://www.ftdichip.com/Support/Documents/DataSheets/ICs/DS\\_Vinculum-II.pdf](http://www.ftdichip.com/Support/Documents/DataSheets/ICs/DS_Vinculum-II.pdf)

[VNC2 Debug Module](#)

[http://www.ftdichip.com/Support/Documents/DataSheets/ICs/DS\\_Vinculum-II.pdf](http://www.ftdichip.com/Support/Documents/DataSheets/ICs/DS_Vinculum-II.pdf)

[Vinculum-II IO Cell Description](#)

[http://www.ftdichip.com/Support/Documents/AppNotes/AN\\_137\\_Vinculum-II%20IO\\_Cell\\_Description.pdf](http://www.ftdichip.com/Support/Documents/AppNotes/AN_137_Vinculum-II%20IO_Cell_Description.pdf)

[Vinculum-II Debug Interface Description](#)

[http://www.ftdichip.com/Support/Documents/AppNotes/AN\\_138\\_Vinculum-II\\_Debug\\_Interface\\_Description.pdf](http://www.ftdichip.com/Support/Documents/AppNotes/AN_138_Vinculum-II_Debug_Interface_Description.pdf)

[Vinculum-II IO Mux Explained](#)

[http://www.ftdichip.com/Support/Documents/AppNotes/AN\\_139\\_Vinculum-II%20IO\\_Mux%20Explained.pdf](http://www.ftdichip.com/Support/Documents/AppNotes/AN_139_Vinculum-II%20IO_Mux%20Explained.pdf)

[Vinculum-II Errata Technical Note](#)

[http://www.ftdichip.com/Support/Documents/TechnicalNotes/TN\\_118\\_VNC2%20Errata%20Technical%20Note.pdf](http://www.ftdichip.com/Support/Documents/TechnicalNotes/TN_118_VNC2%20Errata%20Technical%20Note.pdf)

[Topway LMBABC Display](#)

<http://www.topwaydisplay.com/Pub/Manual/LM6059BCW-Manual-Rev0.3.pdf>

[IMAGE2GLCD utility for creating bit map](#)

<http://www.avrportal.com/?page=image2glcd>

---

## **Appendix B – List of Figures and Tables**

### **List of Figures**

Figure 1.1 - VINCO .....	1
Figure 1.2 – Topway LM6059BCW LCD Module mounted on a Vinco_Proto .....	2
Figure 2.1 – Vinco Graphic Display Demo Block Diagram .....	4
Figure 6.1 – Vinco Graphic Display Demo.....	19

### **List of Tables**

Table 3.1 - Signal Name and Description – LCD Interface .....	5
Table 3.2 - Signal Name and Description – Debugger Interface .....	6

---

## Appendix C – Revision History

Version 1.0	First Release	26 <sup>th</sup> November 2010
Version 2.0	Changed Vinculo brand name to Vinco	14 <sup>th</sup> April 2011



---

**Appendix D Legal Disclaimer:**

*System and equipment manufacturers and designers are responsible to ensure that their systems, and any Future Technology Devices International Ltd (FTDI) devices incorporated in their systems, meet all applicable safety, regulatory and system-level performance requirements. All application-related information in this document (including application descriptions, suggested FTDI devices and other materials) is provided for reference only. While FTDI has taken care to assure it is accurate, this information is subject to customer confirmation, and FTDI disclaims all liability for system designs and for any applications assistance provided by FTDI. Use of FTDI devices in life support and/or safety applications is entirely at the user's risk, and the user agrees to defend, indemnify and hold harmless FTDI from any and all damages, claims, suits or expense resulting from such use. This document is subject to change without notice. No freedom to use patents or other intellectual property rights is implied by the publication of this document. Neither the whole nor any part of the information contained in, or the product described in this document, may be adapted or reproduced in any material or electronic form without the prior written consent of the copyright holder. Future Technology Devices International Ltd, Unit 1, 2 Seaward Place, Centurion Business Park, Glasgow G41 1HH, United Kingdom. Scotland Registered Company Number: SC136640*